

# Classic Sidebelt laying nest

## automatic nest with moveable floor

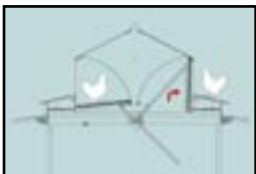

The fully automatic nest systems of Vencomatic are the result of years of development and research. In particular, the main features Vencomatic have strived for are: optimising the egg-quality and egg production, reducing labour costs, a good health and well-being of the birds, and meeting the wishes of the customer.



The sidebelt nest is an automatic laying nest, especially designed for light birds, such as laying hens or light breeders. The nest has a perforated egg belt at the front of the nest. It can be closed with the moveable, self-cleaning floor by means of a maintenance free gear rack.

### Some typical advantages of the Classic Sidebelt Nest:

- Clean and hygienic eggs
- Good hatching egg quality
- Very few eggs outside the nest
- High durability
- Very low level of maintenance
- Less labour

### Some important advantages of the nest:

**Moveable floor:** The nest is closed and opened every day by means of the moveable floor and therefore the floor is cleaned every day. This gives a better egg quality, less chance for broodiness and a good egg production.

**Vencomat:** The floor is fitted with a Vencomat, a natural, rubber mat with a long life-span. It is easy to be cleaned and there is minimum contact with the eggs. The mat reduces cracked

eggs and provides a smooth rolling of the eggs to the egg belt.

**More living area:** The run-in plate above the egg belt may be considered as living area for the bird. Therefore there is a possibility to have a very high bird density in the house.

Other products associated this nest are the Vencoslat, an plastic slat, the Vencobelt, an egg transport system

and the Prinzen farm packer, a simple egg packer.



  
Vencomatic bv Netherlands  
Tel.: +31 (0) 497 517380  
[www.vencomatic.com](http://www.vencomatic.com)



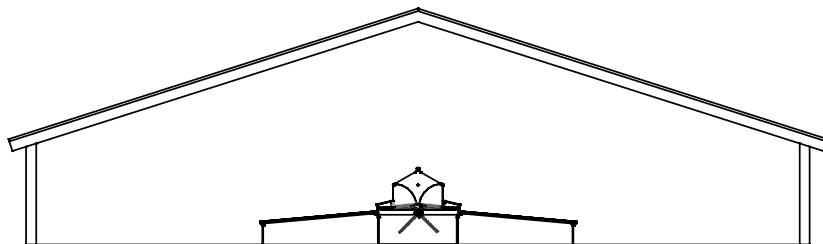

Your local dealer is:

# Classic Sidebelt laying nest

## automatic nest with moveable floor



### Standard Specifications

	<b>ezbn</b>	<b>2ezbn</b>	<b>zbn</b>	<b>2zbn</b>
				
	Single 1 tier nest (2 nestholes)	Single 2 tier nest (4 nestholes)	Double 1 tier nest (4 nestholes)	Double 2 tier nest (8 nestholes)
Nest surface	1,19m <sup>2</sup> /section	2,38m <sup>2</sup> /section	2,38m <sup>2</sup> /section	4,76m <sup>2</sup> /section
Density	125-150 birds	250-300 birds	250-300 birds	500-600 birds
Weight	71 kg/section	130 kg/section	130 kg/section	234 kg/section
Egg belt width	1x250 mm 1x400 mm	2x250 mm 2x400 mm	2x250 mm 2x400 mm	4x250 mm 4x400 mm
Egg belt speed	var. 0-4,7 m/min	var. 0-4,7 m/min	var. 0-4,7 m/min	var. 0-4,7 m/min

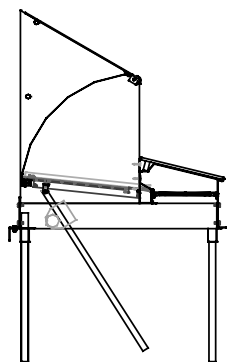

**ezbn**

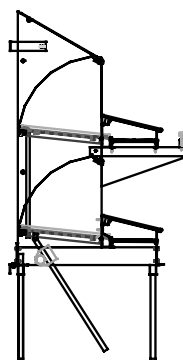

**2ezbn**

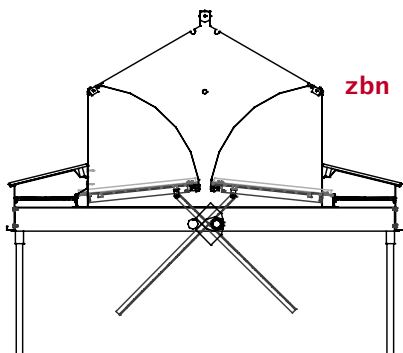

**zbn**

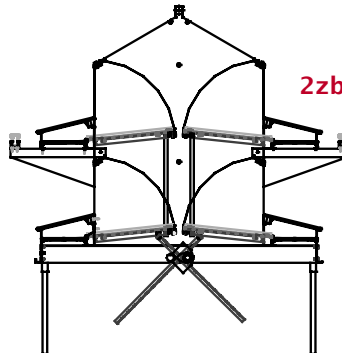

**2zbn**